

BEFOUR

PROFESSIONAL HEALTHCARE SCALES

Tilt & Roll Handrail Scale with BMI

MODEL MX308

Designed to maximize your health care investment, the MX308 scale provides the security of a wrap-around handrail with the ease of tilt & roll mobility. With a 750 pound capacity and specially designed handrails, the patient's weight is determined accurately and quickly, with maximum safety.

The **"tilt & roll" design and large wheels** makes transportation of the scale effortless. Operation is simple and intuitive, even for the first time user. The scale offers many **advanced features which come standard**, including Befour's proprietary MotionLock technology and ECO Weigh battery system for years of use and allows the scale to be used anywhere.

All Befour scales are **built to last**, constructed of anodized aluminum, backed by an **'industry leading' 3-year warranty** and are **Made in the USA**.

FEATURES & BENEFITS

Integrated "Active" Handrail: Allows patient to grasp handrail for support while weight is accurately calculated

Generously Sized Wrap-Around Handrail: Full 25" spacing between handgrips. Unique, heavy-duty, design does not interfere with foot positioning and adds security and stability for patients of all sizes

"Tilt & Roll" Design: Safely weigh patient when scale is stationary, but ready to move at any time

Display Console: LB/KG lockout, programmable settings, BMI output, auto zero, recall, reweigh ability, and more



EMR READY

HANDS-FREE WEIGHING



MotionLock automatically facilitates quick & accurate weight, even for the most unsteady user – no intervention of the care provider or patient required



DISPLAY CONSOLE

Display is used across all Befour's medical scales: Seamlessly move from one model to another with ease

Displays weight, height, and BMI on a single screen

EMR connectivity via serial output or optional wireless module

Programmable User Settings can be set to auto-off, "Hands-Free" Weighing, etc.

'ECO Weigh' battery system provides 100,000 weighings per set of (4) D-cell alkaline batteries (included)

LB/KG Lockout: Toggle between or set to display only your desired unit of measure

3-segment battery life indicator

Large 1" LCD digits

No AC outlet or recharging needed

Tilt & Roll Handrail Scale with BMI

MODEL MX308

SCALE SPECIFICATIONS

SCALE HEIGHT 42"

PLATFORM DIMENSIONS 16" W x 18" D x 1-3/4" H

SYSTEM WEIGHT 31 lbs

WEIGHT CAPACITY 750 lbs (340 kg)

RESOLUTION 0.1 lb (0.05 kg)

ACCURACY ± 0.1 lb (0.05 kg)

POWER SOURCE 4 D-cell alkaline batteries (incl)

BATTERY LIFE 100,000 weighings

CONNECTIVITY USB serial or optional wireless

DISPLAY READOUT 1" LCD digits

WARRANTY 3 years

SHIPPING SPECIFICATIONS

PACKAGED WEIGHT 39 lbs

PACKAGE DIMENSIONS Box (45" x 18" x 10")

SHIPPING METHOD UPS Package

DIMENSIONS

Allow 1" perimeter space - scale should not touch wall

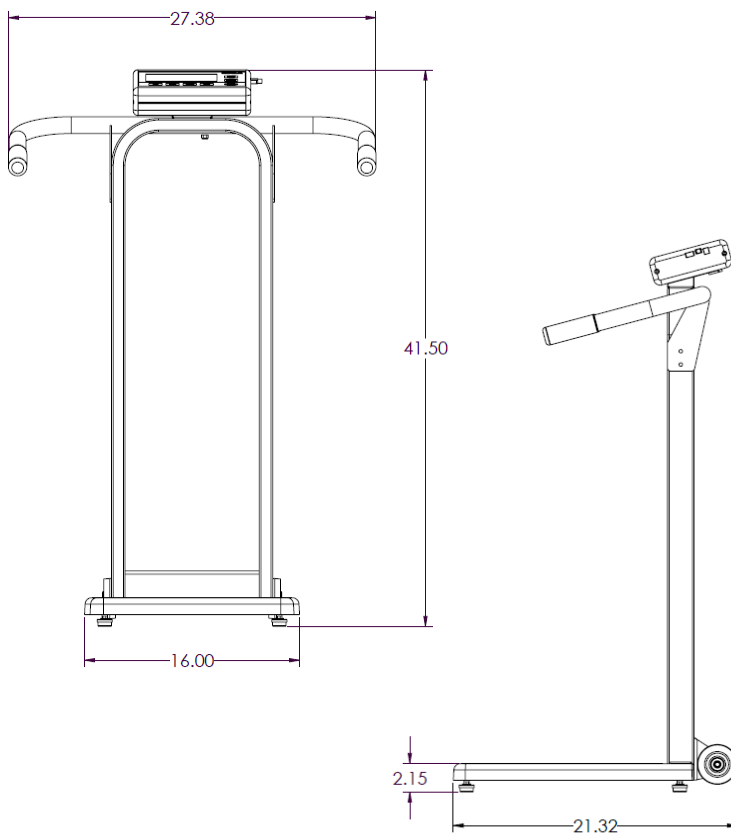

TRANSPORT WHEELS



To move to a new location, simply tilt the scale back on its large 3" wheels and roll away. The scale fits through all standard doorways.

BEFOUR

Befour Inc. | 102 Progress Drive, Saukville, WI 53080 | 800.367.7109 | f: 262.284.5966 | befour.com | sales@befour.com